

**RE160 LE (Less Enclosure) SERIES
LPG ELECTRIC VAPORIZERS**

OPERATION MANUAL

	PAGE
CONTENTS	
1. GENERAL	1
Figure 1-1 - RE160LE Series Vaporizer	B
How to Select an Electric Vaporizer	1
2. PHYSICAL DESCRIPTION	2
Figure 2-1 - Typical RE160LE Series Vaporizer	2
3. FUNCTIONAL DESCRIPTION	3
Control Mode	3
Limits and Safety Features	3
Figure 3-1 - General Schematic for RE160LE Series Vaporizers	4
Table 3-1 - Storage Tank Pressure vs Ambient Temperature Chart	3
4. SPECIFICATIONS	5
Table 4-1 - RE Series Functional Specifications	5
5. OPERATION	6
Start Up and Operating Procedure	6
Figure 5-1 - Typical RE160LE Series Installation	7
6. MAINTENANCE	8
Safety Precautions	8
Emergency Instructions	8
Routine Inspections	8
Purging Gas From The System	8
Gas System Trouble Shooting	9
Warranty Service	9
Table 6-1 - Trouble Shooting	10, 11
Table 6-2 - RE 25 thru RE 400 Replaceable Parts List	12

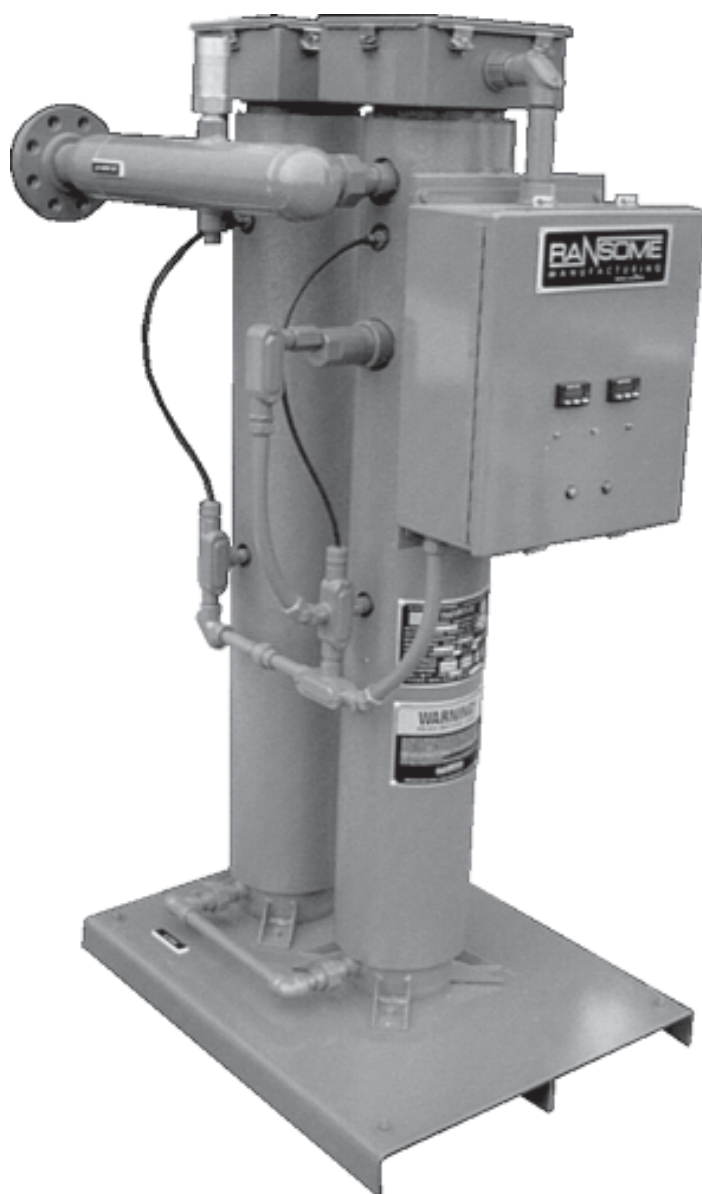

Figure 1-1 - RE160 LE Series Vaporizer

1. GENERAL

1.01 This manual provides a physical and functional description and operating theory necessary for effective use of the Ransome RE160LE (Less Enclosure) Series Electric Vaporizers.

1.02 Ransome RE Series Electric Vaporizers provide an economical, dependable source of Liquefied Petroleum (LP) gas vapor for a wide range of applications up to 400 gallons per hour. Standard units are self-contained and completely prewired. The customer simply connects control and heater circuit power and the electrical installation is complete. They are individually factory-tested on Propane and shipped ready for use. The LP-Gas Inlet and Vapor Outlet are connected to the user's system. The Start button is activated, and the Ransome RE Series Vaporizer goes to work, quietly and automatically.

1.03 LP-Gas is stored as a liquid and used as a vapor. To change it into a vapor, heat must be added at the rate of:

(a) From 785 BTU for each gallon of Propane at -44 F to 441 BTU @ 132 F.

(b) From 808 BTU for each gallon of Butane at -32 F to 634 Btu @ 130 F.

The liquid will then boil, changing to vapor at the rate of:

(c) 36.4 ft. for each gallon of Propane.

(d) 31.3 ft. for each gallon of Butane.

1.04 Ransome RE Series Vaporizers develop the heat required for vaporization of LP-Gas. Operating on temperature control, the heaters function only as needed to maintain proper temperature.

1.05 Features of the RE Series Vaporizers include the following:

1. ASME code pressure vessel shell(s) with internal heat exchange cylinders. Each vessel is constructed of carbon steel material for its high strength and thermal conductivity characteristics.

2. Ransome's unique liquid level float switch configuration. The high liquid level prevents liquid from entering the outlet.

3. Precision operating and high temperature switches. The electronic operating temperature controller operates the heater circuit(s) for the desired outlet set vapor temperature. The high temperature switch(s) turn the vaporizer off in case of runaway heater malfunction.

4. Inlet solenoid valve, in conjunction with the high liquid level switch, closes the inlet preventing the liquid from spilling over to the outlet.

5. Electric resistance cartridge heaters. They are located inside the heat exchange cylinders which are in turn located at the center of the vaporizer shell(s).

6. ASME stamped relief valve. Each vaporizer unit is adequately protected in accordance with NFPA 58 and California Title 8 codes.

7. All controls are located inside an enclosure protected from the weather.

8. All sizes are capable of infinite turndown and will maintain a ready supply of vapor from zero load to full capacity. At no load, only enough will be generated to maintain temperature and to prevent condensation. Warm liquid bath provides continuous heat source, eliminates starting lag when accommodating widely fluctuating loads.

How To Select an Electric Vaporizer

1.06 Determine the total amount of LP-Gas Vapor required. Add up the maximum inputs of all the gas-using equipment in the system from manufacturer's data plate or literature, usually expressed in BTU/HR. Be **SURE** this is correct. If in doubt, contact the manufacturer's of the equipment.

(a) Calculate required capacity as follows:

$$Q = \frac{Ht \times Fd}{91,690}$$

Where:

Q = Required Capacity in Gallons/Hour Propane.

H = Total Input Required, BTU/Hour

Fd = Load Variation Factor

- 1.0 for Gradual Load Changes
- 1.1 for Rapidly Fluctuating Load Changes
- 1.2 for Temperatures Below Minus 30 F.

2. PHYSICAL DESCRIPTION

2.01 The Ransome RE Series Vaporizers are all similar in design and construction. They are designed for mounting on a concrete slab, outdoors, in varied weather conditions. The heat exchanger is mounted on a steel base and thermally insulated.

2.02 The principle difference between models is the capacity, ranging from 25 to 400 gph.

electric inlet valve to control LP-Gas level in the Vaporizer. Most of the system components are the same or similar between models. Capacity is increased by the vaporizer tube size and by paralleling Vaporizer Tubes.

2.03 Figure 2-1 illustrates a typical Vaporizer and is provided with key letter callouts for Physical dimensions.

The Model RE 25, 50 and 80 utilize an internal Float switch and

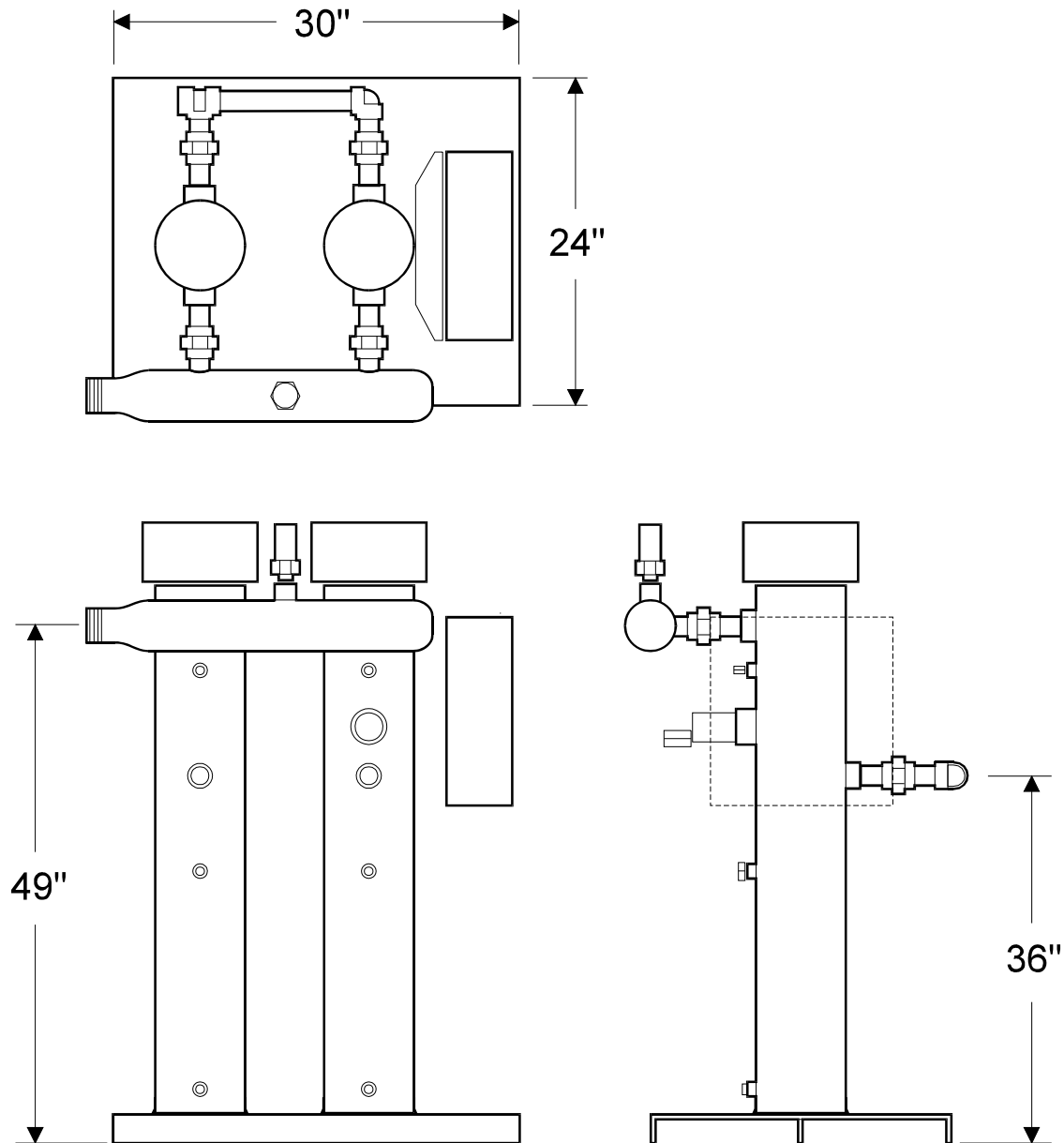

Figure 2-1 - RE160LE Series Physical Specifications

3. FUNCTIONAL DESCRIPTION

3.01 Figure 3-1 illustrates the general schematic for RE Vaporizers and is functionally equivalent for all RE Series Vaporizers.

3.02 LP-Gas is supplied to the vaporizer inlet from the user's Storage Tank(s) System at a pressure dependent on temperature. (Refer to Table 3-1)

(a) RE25 thru 400 use an internal float switch and electric inlet valve to limit liquid level and prevent flooding.

Table 3-1 - Storage Tank Pressure vs. Ambient Temperature Chart

Temperature (F)	Approximate Pressure PSIG	
	Propane	Butane
110	220.0	46.0
100	190.0	37.0
90	165.0	29.0
80	140.0	22.0
70	120.0	16.5
60	102.0	11.5
50	86.0	6.9
40	72.0	3.0
30	58.0	
20	47.0	
10	37.0	
0	28.0	
-10	20.0	
-20	13.5	
-30	8.0	
-40	3.6	

Control Mode

3.03 The RE Series Electric Vaporizer uses electronic temperature controller with an RTD (Resistance Temperature Detector) probe input to control the heat required for vaporization. The control mode used is time proportioning. This provides for precise control of process temperature. A time proportioning control operates in the same way as an ON/OFF control when a process temperature is far enough away from set point to be outside the proportional band. When process temperature approaches set point and enters the proportional band, the output device is switched ON and OFF at the established cycle time. At the lower limit of the band, the ON time is considerably greater than the OFF time. As the process temperature more closely approaches set point, the ratio of ON to OFF changes; the amount of ON time decreases and the OFF time increases. This change in heat delivered provides a modulating effect which results in less process temperature overshoot. The ON and OFF cyclic action continues until a relationship of equal ON and OFF is attained. At that time, the system will stabilize such that process temperature is controlled at a point just below the set point.

The process temperature does stabilize with resultant droop. This condition will remain providing there are not work load changes in the system. The overshoot is typical of proportional control systems on initial temperature rise or during a change in demand.

Limits and Safety Features

3.04 RE Series Electric Vaporizers have two high temperature protection devices to protect the system in the event of an over-temperature condition. A separate precision Snapdisk type high temperature switch is installed in the potential hottest part of the heat exchange vessel. Incorporated within the electronic temperature controller is another high temperature monitor to provide protection against high temperatures. In addition the electronic temperature controller protects against a low temperature condition in the event of over capacity or heater failure and the resultant loss of heat. In any of the above cases, a safety shutdown will occur requiring a manual restart once the problem has been rectified.

3.05 The Vapor Outlet Line pressure is monitored by the Safety Relief Valve which opens when the line pressure exceeds 250 psig. The user should provide a Shut-Off Valve and Outlet Pressure Regulator on the Vapor Outlet Line. The Pressure Regulator should not be over 24 inches from the Vaporizer.

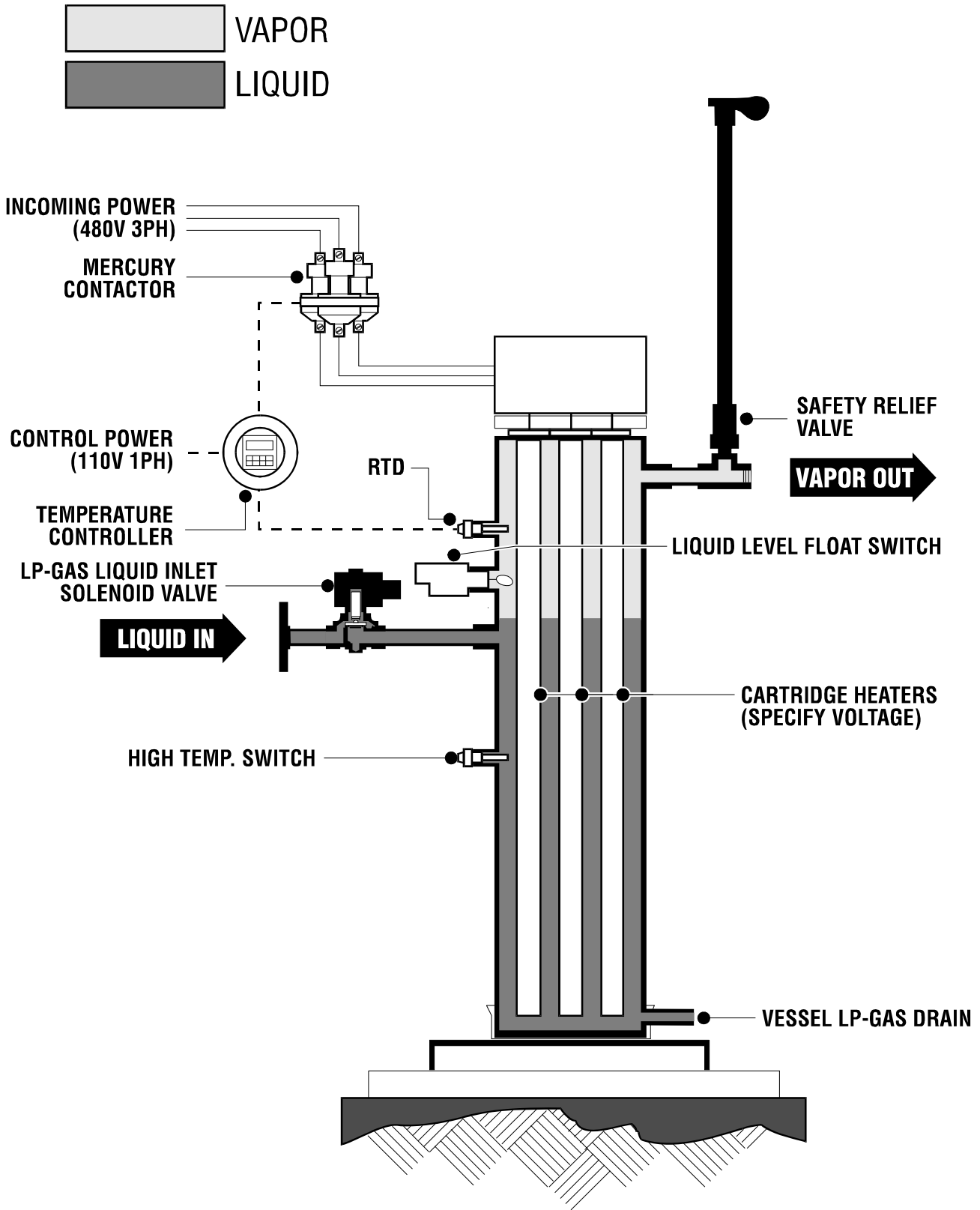

Figure 3-1 - General Schematic for RE Series Vaporizers

4. SPECIFICATIONS

4.01 Table 4-1 will provide the user with tabulated performance specifications for RE Series Vaporizers. Figure 2-1 illustrates the physical specifications of respective RE Vaporizers. The user will find this useful when planning new installations.

Selection Chart

GAL/HR	KG/HR	CF/HR	Approximate Shipping Weight		Ransome Model
			LB.	KG.	
25	48	912	300	136.1	RE 25
50	96	1825	300	136.1	RE 50
80	153	2920	425	192.8	RE 80
160	307	5840	725	328.9	RE 160
240	460	8760	950	430.9	RE 240
320	614	11680	1200	544.3	RE 320
400	768	14600	1400	635.1	RE 400

* Rated capacity in GPH of Propane @ 0 degrees F with a minimum vapor outlet temperature of 100 F.

Note: Rated capacity for Butane will be lower than that of Propane.

Electrical

KW	Number of Tubes	Amps per Line				Conduit Size Heater Circuit	Number of Lines	Ransome Model
		120V-1Ph	240V-1Ph	240V-3Ph*	480V-3Ph*			
8	1	66A	33A	19A	10A	3/4"	2 or 3	RE 25
16	1		66A	38A	19A	3/4"	2 or 3	RE 50
25	1			62A	31A	3/4"	3	RE 80
50	2				2 @ 31A=62A	3/4"	6	RE 160
75	3				3 @ 31A=93A	1"	9	RE 240
100	4				4 @ 31A=124A	1"	12	RE 320
125	5				5 @ 31A=155A	1-1/4"	15	RE 400

* If 3 phase power, the heater cartridges are connected in delta configuration.

Note: All control circuits 120V AC, 60Hz, 10Amp. All control circuit conduit 1/2".

Table 4-1 - RE Series Functional Specifications

5. OPERATION

5.01 The intent of Part 5 is to give the LP-Gas user general information on installation and turn-on procedure for the Ransome RE Series Vaporizers. Each user's application will differ slightly, but it is hoped the user will gain from these generalized instructions.

5.02 After consulting with the Ransome Sales and Service Engineer or Distributor and reviewing Figure 5-1, the user will make a plan for the LP-Gas storage and Vaporizer location.

5.03 When the Ransome equipment arrives, examine the shipping container for obvious shipping damage. All Claims for shipping damage should be made to the shipper, not to Ransome Manufacturing or the Distributor. Obvious workmanship problems or incomplete shipments should be immediately referred to Ransome Manufacturing (or Distributor) following the warranty service procedures described in Part 6.

CAUTION

Only a trained, experienced vaporizer serviceman should inspect, test, start up or service Ransome equipment.

Start Up and Operating Procedure

5.04 All RE Series Vaporizers are factory tested using Commercial Propane. Ransome Vaporizers are thoroughly tested at the factory and assured to be free from leaks. However, vibration and jarring during subsequent handling, shipment and installation can cause leaks.

The factory recommends:

(a) Use a good quality liquid leak detecting solution, for leak checking. This is available for subfreezing temperatures as needed. A thorough leak test using one of these solutions or equivalent leak detector must be conducted after installation and any leaks must be repaired prior to operation of the Vaporizer.

CAUTION

Do not use matches or other flames to conduct leak tests.

This start-up procedure assumes a complete, proper installation of the entire gas system including storage tank(s), valve, piping, bypass valves, etc., and including any required electrical power. All installations must be in accordance with NFPA No. 58 Standards, state, provincial or local regulations, codes and laws. The procedure assumes use of clean, contamination-free LP-Gas. Close ALL VALVES in the system prior to startup. Then proceed as follows:

Step 1 - Allow a qualified electrician to complete all electrical connections from customer supply power to the RE vaporizer control panel. Be sure to conform to all applicable electrical installation codes.

Step 2 - Prime the system by slowly opening valves in the LP-Gas liquid line one at a time between the storage tank and the RE vaporizer inlet, starting at the storage tank. If a pump is incorporated, be sure to open valves on the manual bypass line to avoid excessive differential pressure and possible damage. Do not start the pump at this time.

Step 3 - Slowly open the manual inlet valve to the RE vaporizer admitting LPG liquid to the vaporizer solenoid valve. Be sure that all valves downstream of the vaporizer are closed.

Step 4 - With service power connected, push the vaporizer's "ON" button, the heaters will be cycled on and off time proportionally by the electronic temperature controller. Note that initially, with the outlet valve closed, only a small amount of liquid may enter the vaporizer. The vessel will heat up and overshoot the set point on startup. This is normal.

Step 5 - When the main heaters automatically shut off, the vaporizer is ready for operation.

Step 6 - Slowly open the vapor outlet line valve to fill service line to load. The RE vaporizer is now on line and ready to supply vapor upon demand. It is recommended that the vaporizer system remain "ON" to maintain temperature and eliminate any possibility of corrosion from condensation.

Typical Installation - Principal Features and Operating Characteristics

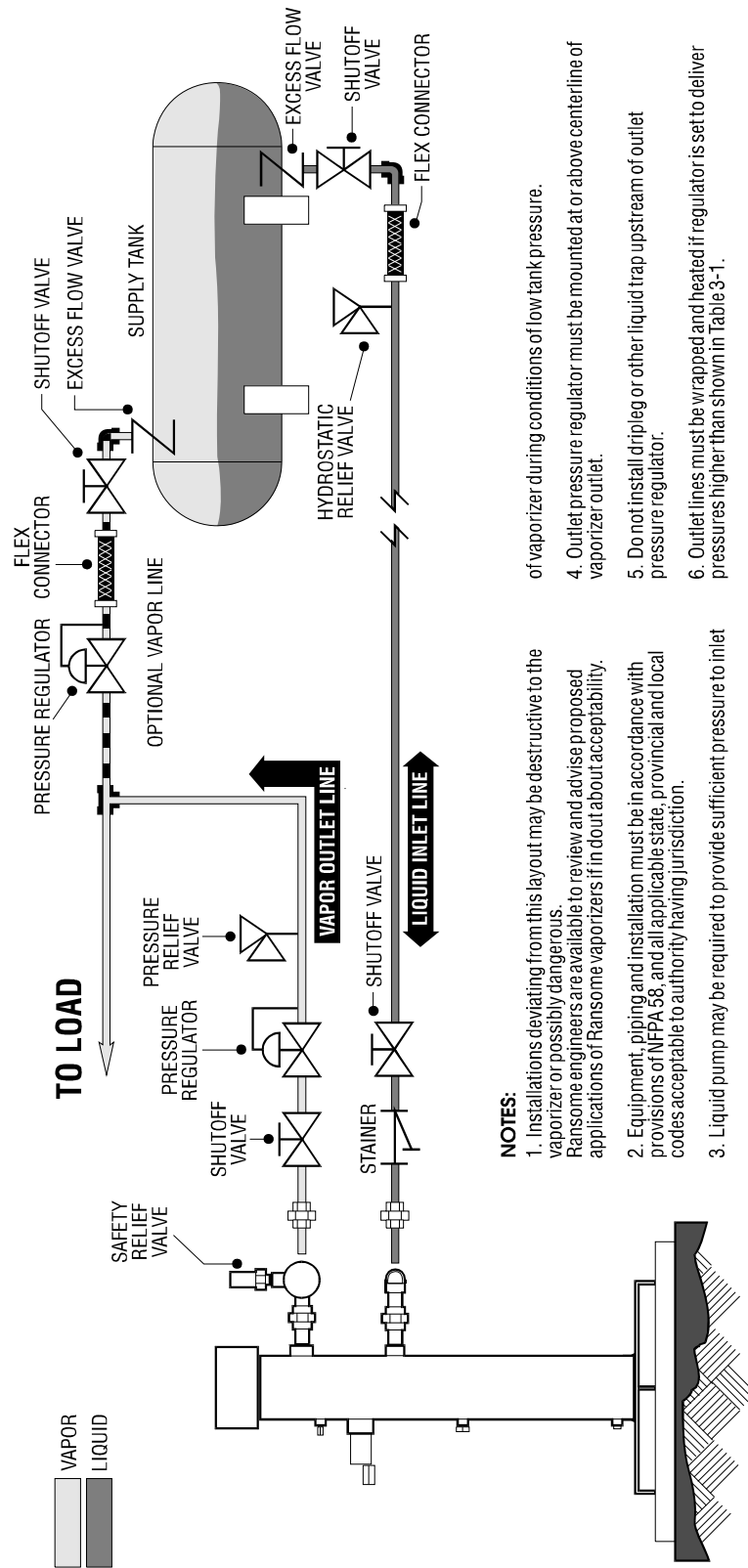

NOTES:

1. Installations deviating from this layout may be destructive to the vaporizer or possibly dangerous. Ransome engineers are available to review and advise proposed applications of Ransome vaporizers if in doubt about acceptability.
2. Equipment, piping and installation must be in accordance with provisions of NFPA 58, and all applicable state, provincial and local codes acceptable to authority having jurisdiction.
3. Liquid pump may be required to provide sufficient pressure to inlet of vaporizer during conditions of low tank pressure.
4. Outlet pressure regulator must be mounted at or above centerline of vaporizer outlet.
5. Do not install dripleg or other liquid trap upstream of outlet pressure regulator.
6. Outlet lines must be wrapped and heated if regulator is set to deliver pressures higher than shown in Table 3-1.

Figure 5-1 - Typical RE Series Installation

6. MAINTENANCE

6.01 Maintenance procedures in Part 6 should be performed in accordance with local regulations and the user's maintenance plan.

Safety Precautions

6.02 The RE Series Vaporizers contain flammable gas under pressure while in normal operation. Any gas leaks within the vaporizer system or in any part of the installation are potentially dangerous and must be eliminated immediately or a fire may occur. Any odor, gas or dark oily stains on joints or fitting indicate a possible gas leak. If such a leak does exist, pilots or other source of ignition must be immediately extinguished. Electrical power should be disconnected at a location remote from the suspected leak.

6.03 Thorough inspections for leaks should be conducted frequently. Any leaks should be repaired immediately. Since this equipment, as well as any other components in the installation uses threaded joints, gaskets and "O" rings and are subjected to vibration and thermal stresses, the possibility of leaks developing over a period of time is always present.

Emergency Instructions

6.04 If a large leak is discovered, do not attempt to affect repair.

- (a) Evacuate all personnel from the area.
- (b) Call the Fire Department.
- (c) If it can be done with safety, shut off the Main Gas Supply Valve(s) at the LP-Gas Storage Tank(s)

The leak will stop when all gas downstream from the Gas Supply Valve(s) has been exhausted.

- (d) Make certain all gas has safely dispersed before attempting repairs.

Routine Inspection

6.05 LP-GAS INLET VALVE(S) to Vaporizer should be disassembled and inspected at least ONCE A YEAR and more often if the equipment is in heavy use and also at any time an abnormality is detected. Any parts that are worn or show deterioration should be repaired.

6.06 OPERATING SWITCHES AND CONTROLS should be checked for correct performance at frequent intervals. Repair or replacement should be accomplished at the first

indication of sticking, erratic performance or any abnormal condition.

6.07 SAFETY RELIEF VALVES should be replaced at any time possible damage is suspected. Vent piping connected to Safety Relief Valves must be kept open, free from condensation, ice or other foreign material that might restrict release of excessive pressure in an emergency.

6.08 VAPORIZER TUBES should be inspected for corrosion at regular intervals. If signs of corrosion or other damage are found, the Vaporizer Tube should be reinspected, tested and approved by a Certified A.S.M.E. Code Inspector. Any rejected Vaporizer Tube must be replaced.

6.09 EXTERIOR PAINT - Keep all external surfaces well painted to prevent deterioration and rust.

Purging Gas From The System

6.10 If service requires removal of gas from the system, DO NOT merely vent gas to atmosphere. This could result in the possibility of injury or damage.

- (a) A Flare Burner should be installed at a safe distance from any gas leakage.
- (b) Dispose of gas by burning.
- (c) Make sure all gas is actually removed from the equipment before any connections are loosened.

6.11 If LP-Gas liquid is present in the Ransome equipment, it will chill as the pressure is relieved, slowing the rate at which it will boil and discharge as vapor through the Flare Burner. **BE CERTAIN** all liquid is actually vaporized before loosening any connections. The presence of frost on the outside of a component part is an indication of the presence of LP-Gas liquid and no connections should be loosened until it melts. The use of a heat source, such as a forced air heater, may expedite this process in cold weather.

6.12 All servicing must be done in a safe, thorough, step-by-step manner. If in doubt about what to do, the serviceman should:

- (a) Consult the Operation Manual.
- (b) Contact the gas system installer.
- (c) Contact Ransome Manufacturing, following the instructions under Warranty Service in this manual.

Gas System Trouble Shooting

6.13 The trouble shooting procedures described in Table 6-1 are intended to help a serviceman isolate the cause of trouble encountered during routine operation to a replaceable part listed in Table 6-2 and. Only the kinds of trouble more likely to be encountered in service are listed. The list is by no means comprehensive. The Probable Cause column of Table 6-1 lists in order of most likely occurrence. To make the best of these trouble shooting procedures, the serviceman should be thoroughly familiar with the Physical and functional Descriptions of the Ransome system described in Part 2 and 3 of this manual.

6.14 Before beginning any trouble shooting, make certain the Ransome Vaporizer has been properly installed. All system components including storage tanks, valves, piping, pumps and bypass valves must conform to NFPA No. 58 Standards and all state, provincial or local regulations, codes and laws.

Warranty Service

6.15 Faulty system components should be returned to Ransome Manufacturing following the conditions set out in the Warranty. Defective material or technical questions should be referred to:

RANSOME MANUFACTURING
3495 South Maple Avenue
Fresno, California 93725
U.S.A.

Phone (559) 485-0979 / Fax (559) 485-8869

When the material is returned to Ransome, the following information will expedite repair or replacement and return if it is included:

- (a) Complete Material Return Authorization (MRA) form. These can be obtained from Ransome Customer Service upon request.
- (b) The name and area code - telephone number of the individual most familiar with the failure.
- (c) A brief statement of the problem with the unit.
- (d) Make(s) of other gas equipment in the user's system.
- (e) The approximate date and Purchase Order Number for the Ransome equipment (if known).
- (f) The Model and Serial Number of the Ransome equipment.

Table 6-1 - Trouble Shooting

Symptom	Probable Cause	Remedy
Solenoid valve does not open	<ol style="list-style-type: none"> 1. Bad electrical connection. 2. Solenoid coil faulty. 3. High level float in open position. 4. Solenoid valve blocked. 	<p>Check connections and repair as needed.</p> <p>Replace coil.</p> <p>Reduce demand to lower liquid level. Dislodge float if bound. Check switch for continuity.</p> <p>Disassemble, clean, repair and replace worn or damaged parts as needed.</p>
Heaters will not turn off	<ol style="list-style-type: none"> 1. System at capacity. 2. Faulty contactor. 3. Fault in Temperature Control Circuit (Controller and RTD). 	<p>Normal operation.</p> <p>Check and replace if necessary.</p> <p>Check components for any physical damage and replace as needed.</p>
Unit shuts down	<ol style="list-style-type: none"> 1. Exceeded High Temperature limit. 2. Low temperature limit tripped. 3. Loss of control circuit power. 	<p>Check unit for proper fuel supply and contactor operation.</p> <p>Operate unit within its rated capacity. Verify all heaters are operating at rated wattage.</p> <p>Check incoming control and heater circuit power. Even a momentary loss of power will cause the unit to shut down.</p>
Unit overheats	<ol style="list-style-type: none"> 1. Faulty contactor. 2. Fault in Temp. Control Circuit. 3. Unit dry due to loss of product. 	<p>Check and replace if necessary.</p> <p>Check component for any physical damage and replace as needed.</p> <p>Verify and assure adequate liquid supply to inlet of vaporizer.</p>
Unit will not maintain temp.	<ol style="list-style-type: none"> 1. System beyond its rated capacity. 2. Loss of power to heater control circuit. 3. Loss of wattage in one or more heaters. 4. Fault in Temp. Control Circuit. 	<p>Reduce demand to rated capacity.</p> <p>Verify electrical power to heaters.</p> <p>Verify heaters are operating at rated wattage.</p> <p>Check components for physical damage and replace as needed.</p>

Table 6-1 - Trouble Shooting (Continued)

Symptom	Probable Cause	Remedy
Insufficient capacity	<ol style="list-style-type: none"> 1. Unit over-capacitated. 2. Loss of wattage in one or more heaters. 3. Liquid supply inadequate. 4. Inlet solenoid not completely open or strainer clogged. 5. Valves in system not completely open. 	<p>Reduce demand to rate capacity of unit.</p> <p>Verify heaters are operating at rated wattage.</p> <p>Verify and assure adequate supply of liquid to inlet of vaporizer.</p> <p>Inspect and disassemble, clean, repair as needed. Clean strainer.</p> <p>Verify that all valves (excess flows and shutoffs) are completely open.</p>
Liquid at LP-Gas Outlet	<ol style="list-style-type: none"> 1. Unit over-capacitated. 2. Loss of wattage in one or more heaters. 3. High level float switch not operating properly. 	<p>See "Insufficient Capacity".</p> <p>Verify heaters are operating at rated wattage.</p> <p>Reduce demand to lower liquid level. Dislodge float if bound. Check switch for continuity.</p>
Safety relief valve	<ol style="list-style-type: none"> 1. Flow back to liquid storage blocked 2. Check valve installed in liquid supply line preventing flow back into storage tank. 	<p>Verify there are no blockages in liquid supply line.</p> <p>Remove all check valves in liquid supply line.</p>

Table 6-2 - RE 25 thru RE 400 Replaceable Parts List

Item	Ransome Part Number	Manufacturer's Part Number	Description
1	01-55900		RE80-400 Resistance Heater 8470 Watts 49-1/2" long. Please specify voltage.
2	01-55900		RE50 Resistance Heater 5300 Watts 30-1/4" long. Please specify voltage.
3	01-55900		RE25 Resistance Heater 2670 Watts 30-1/4" long. Please specify voltage.
4	01-55685-75	335NO-120	3-Pole Mercury Relay
5	18-59005-50	T2110-0000	Electronic Temperature Controller
6	18-59006-20	RTD-810	RTD (Resistance Thermometer Detector) Probe
7	06-57010-05	08-819321	High Temperature Switch set @ 300 Deg. F
8	M-1075-01		SOR Level Control Switch Capsule
9	14-58011-07	8210B26	3/4" Solenoid Valve RE25-160
10	14-58012-10	8211B27	1" Solenoid Valve RE240-400
11	14-58205-00		1" Inlet Check Valve RE240 thru RE400
12	01-60000-20		Circuit Board Safety Limit Out-Put Control.