

Selection Chart

If your peak load requirements are up to			Vaporization Required GPH Propane	Air Required SCFM	Line Sizes (IN.)			RANSOME MODEL
MILLIONS OF BTU/HR	Thousands of SCFH Natural Gas (1)	Thousands of SCFH Mixed Gas (2)			Air In	Propane In	Mix Out	
22.1	22.1	15	244	102	2	2	6	MPM15
44.25	44.25	30	488	204	2	2	6	MPM30
73.75	73.75	50	813	340	2	2	6	MPM50
110.6	110.6	75	1,220	510	2	2	6	MPM75
148	148	100	1,626	680	2	2	6	MPM100
221	221	150	2,440	1,020	3	2	6	MPM150
296	296	200	3,253	1,360	4	3	6	MPM200
369	369	250	4,066	1,700	4	3	6	MPM250
443	443	300	4,879	2,040	4	3	8	MPM300
738	738	500	8,132	3,400	4	3	8	MPM500
1,106	1,106	750	12,198	5,100	4	3	8	MPM750
1,475	1,475	1,000	16,264	6,800	6	4	12	MPM1000

Selection Chart - SI Conversion

If your peak load requirements are up to			Vaporization Required KG/HR	Air Required M3/M	Line Sizes (IN.)			RANSOME MODEL
M KCAL/HR	M3/HR Natural Gas (1)	M3/HR Mixed Gas (2)			Air In	Propane In	Mix Out	
5.57	626	425	469	2.89	5	5	15	MPM15
11.15	1,253	850	937	5.78	5	5	15	MPM30
18.59	2,089	1,416	1,561	9.63	5	5	15	MPM50
27.87	3,132	2,124	2,343	14.44	5	5	15	MPM75
37.30	4,191	2,832	3,123	19.26	5	5	15	MPM100
55.69	6,259	4,248	4,686	28.89	7	5	15	MPM150
74.59	8,383	5,664	6,247	38.52	10	8	15	MPM200
92.99	10,450	7,080	7,808	48.18	10	8	15	MPM250
111.64	12,546	8,496	9,370	57.77	10	8	20	MPM300
185.98	20,900	14,160	15,617	96.29	10	8	20	MPM500
278.71	31,322	21,240	23,425	144.43	10	8	20	MPM750
371.7	41,772	28,320	31,234	192.58	15	10	30	MPM1000

(1) Natural Gas; S.G.U. = .6, Gross Heat Content 1000 BTU/Cu. Ft. (2) Mixed Gas; Propane-Air, S.G.U. = 1.31, Gross Heat Content 1480 BTU/Cu. Ft.

Standard Specifications

Standard units are built to Factory Mutual specifications. Factory-tested and calibrated to deliver 1.31 nominal specific gravity (1480 BTU/C.F.) propane air mixture. Specific desired mixed gas pressure from 10 to 60 PSI.

MPM Options

Option	Description	Add Suffix
Outage Panel	Provides cause of safety shutdown, to simplify service. Includes alarm lights for high and low propane and mixed gas pressures, high and low air pressures, low mixed gas temperatures, high air ratio, and alarm acknowledge switch.	C
High Pressure Design	Specify desired mixed gas pressure over 60 PSI.	H

Warranty

Ransome Manufacturing, 3495 South Maple Avenue, Fresno, California, warrants to all parties all equipment manufactured and sold by it to be free from defects in material or workmanship under normal use and service, when installed and used in accordance with all applicable state and local codes, regulations and laws in accordance with National Fire Protection Pamphlet 58. Ransome Manufacturing agrees to repair or replace any equipment which its examination reveals to have been defective due to faulty workmanship or material, if returned to factory, transportation charges prepaid. Deviations from recommended applications, system design, installation and service practices, as well as deterioration or wear due to foreign materials or contamination present in LP-Gas or air shall be considered as abuses and render this warranty void. This warranty applies for a period of one year from date of installation, but not more than eighteen months after shipment from factory.

This warranty is expressly in lieu of all other warranties expressed or implied, and of all obligations or liabilities on its part for damages including but not limited to consequential damages, following the use or misuse of equipment sold by it. No agent is authorized to assume any liability for Ransome Manufacturing, except as set forth above.



Engineering and Equipment Manufacturing

**MPM Series
LP-Gas
Modulating
Proportioning
Mixers**



3495 South Maple Avenue • Fresno, California 93725 • USA
Telephone (559) 485-0979 • Fax (559) 485-8869

The MPM Series Mixer

Gas is precisely controlled by holding a fixed differential pressure across a control valve through which LP-Gas flows at constant pressure. Air flows through a second, identical control valve, across which a fixed differential pressure is maintained by controlling incoming air flow. Flow of gas and air then enters a common chamber where it is mixed and passes to the outlet. Operating conditions are continually monitored by a combination of pressure and temperature switches and controls. Should an unsafe condition develop, all valves in the mixer will close, effectively preventing any flow until the condition is corrected. Gas-air ratio can be easily changed by adjusting the set point of the air controller.

Why a Modulating Proportioning Mixer?

A Ransome Modulating Proportioning Mixer blends LP-Gas and air in a precise ratio to provide a fuel compatible with natural gas. It is designed for continuous duty, to provide fuel when the normal gas supply is reduced or cut off. It can be used to completely replace the natural gas, or to blend with the gas during peak load periods. The Ransome MPM (Modulating Proportioning Mixer) is the finest piece of equipment of its type on the market today. These Mixers are fabricated with "OFF THE SHELF" items that are serviceable anywhere in the world. These Mixers work on a variable orifice constant pressure principle using Fisher Process, and Flow Control Valves with instrumentation. Because of the unique single actuator control mechanism, super fine tuning is achieved with turn down ratios of 100 to 1. Ransome employs the throttle VEE-BALL with a rotary shaft in its design, thus eliminating vertical shaft movement and drag. The precise contouring of the V-Notch Ball provides a nearly equal percentage flow characteristic, with unrestricted straight through flow design providing greater capacity than many other conventional valves. Splined valve shafts and clamped actuator levers minimize lost motion and improve control accuracy.

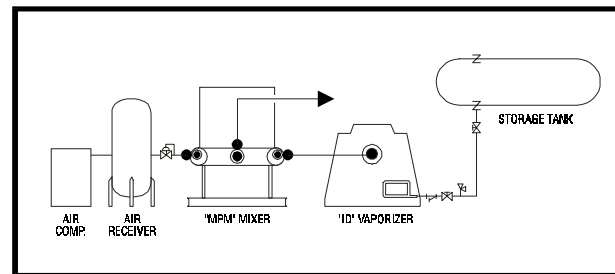
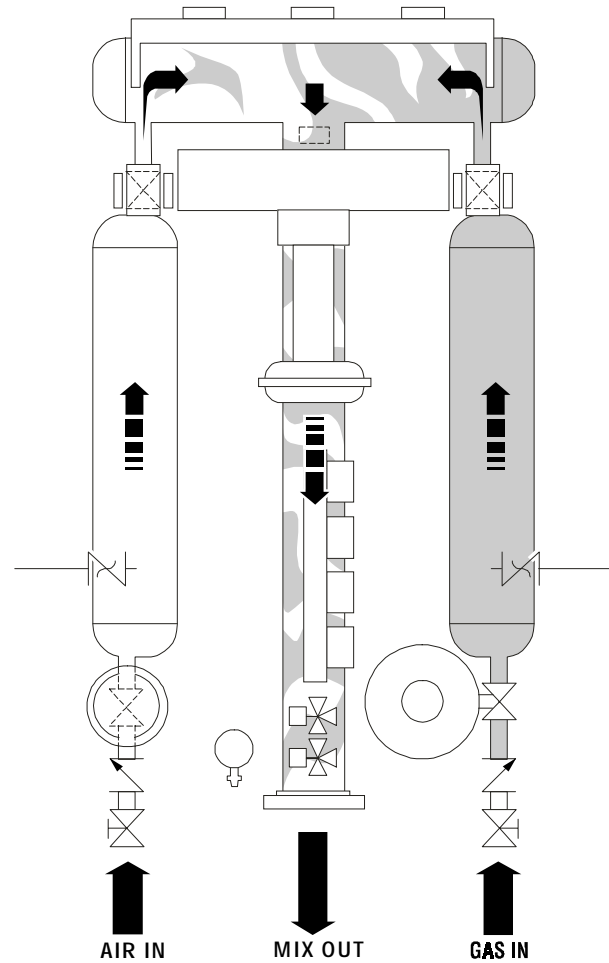

Features

1. Completely automatic operation.
2. 100 to 1 turndown ratio.
3. Simple installation, requires only three piping connections.
4. 100% fail-safe operation.
5. Provides continuous operation without surge tanks.
6. Available in a complete line of standard units from 15,000 to one million SCFH mixed gas, with sendout pressures available from 10 to 200 P.S.I.
7. Completely packaged on a skid, ready to connect to piping system.
8. Listed by Factory Mutual.
9. Compact, modular design; requires only 5' x 15' floor space for up to MPM-300 size.
10. Quick response controls to maintain accurate LP-Gas-Air ratio even during varying conditions.
11. Simple, one-lever adjustment of LP-Gas-Air ratio.
12. Can be combined with flow recording and control equipment for automatic peak load shaving

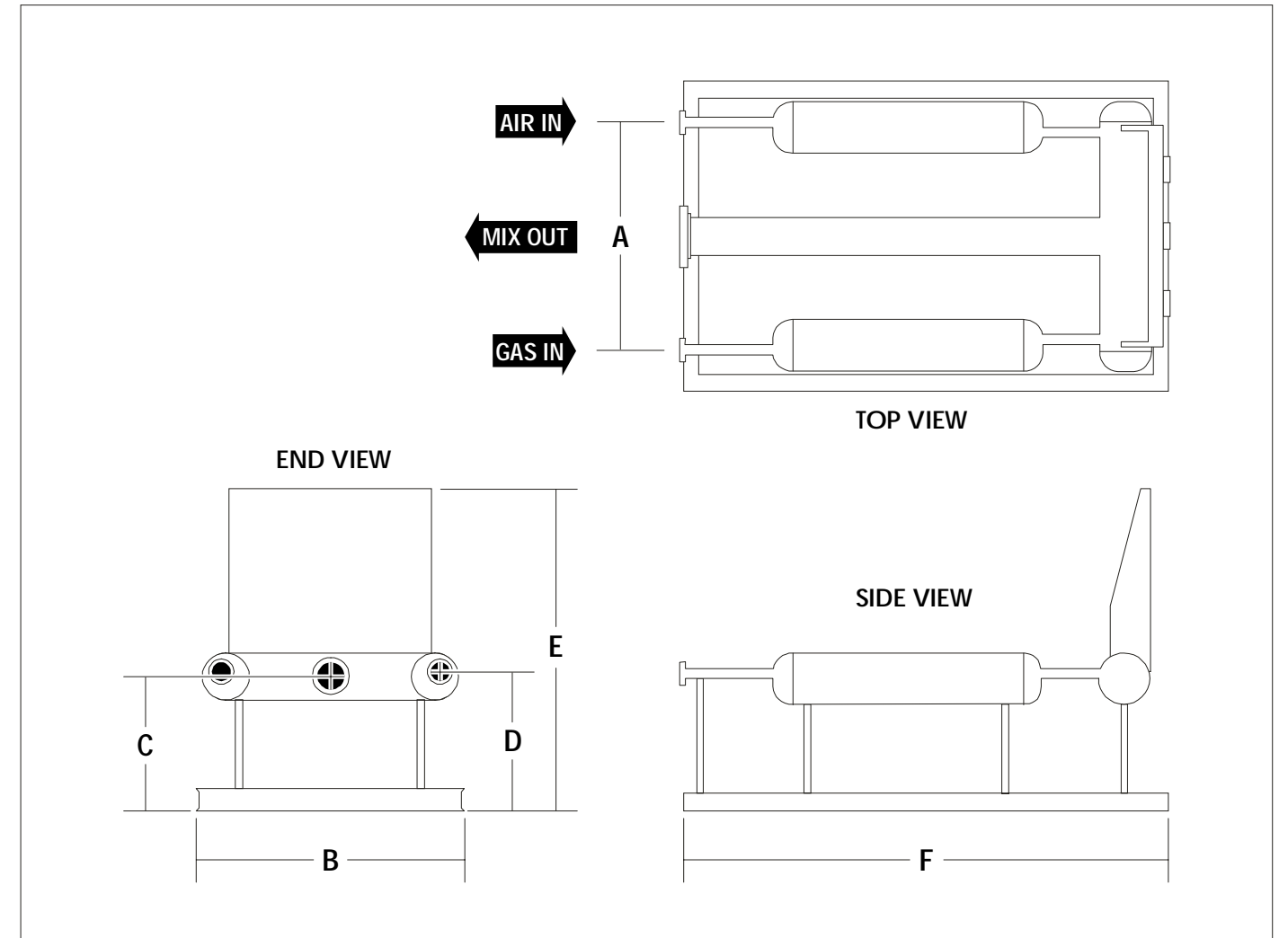

Ransome Model	DIMENSIONS, IN.						Approx. Weight LB.
	A	B	C	D	E	F	
MPM15	48	60	28.5	30	75	107	1,650
MPM30	48	60	28	30	76	113	1,750
MPM50	48	60	27.75	30	77	119	1,950
MPM75	48	60	27.5	30	78	123	2,250
MPM100	48	60	27	30	79	128	2,350
MPM150	48	60	26.75	30	80	134	2,550
MPM200	48	60	26.5	30	81	140	2,950
MPM250	48	60	25.75	30	82	148	3,300
MPM300	48	60	24.75	30	83	154	3,900

Ransome Model	DIMENSIONS, CM.						Approx. Weight KG.
	A	B	C	D	E	F	
MPM15	122	152	72	76	190	272	748
MPM30	122	152	71	76	193	287	794
MPM50	122	152	70	76	196	302	885
MPM75	122	152	70	76	198	312	1,021
MPM100	122	152	69	76	201	325	1,066
MPM150	122	152	68	76	203	340	1,157
MPM200	122	152	67	76	206	356	1,338
MPM250	122	152	65	76	208	376	1,497
MPM300	122	152	63	76	211	391	1,769

Models MPM-500, MPM-750 and MPM-1000 also available. Consult factory for sizing information.

Standard Equipment

- Fisher Valves and controllers with adjustable gain and integral action.
- Manual loader for easy recalibration.
- Back checks protect Air and LP-Gas lines in event of compressor failure.
- All valves and controls are fail-safe, shutting down in system in event of emergency.
- Safety Relief Valves for over-pressure protection.
- All electrical components meet NEC code Class I, Group D, Division I. Division II also Available.